



COLORDMD

Installation Instructions
for **WPC95 - CHROMA**

Congratulations on the purchase of a new ColorDMD display. The ColorDMD will enhance your pinball machine by introducing *color* to the dot matrix display graphics produced by the game.

Tools Required: • Phillips Screwdriver



Be sure to turn **OFF** the power to the pinball machine before installing the ColorDMD display.

- STEP **1** Carefully remove the translite from the backbox and then lower the speaker panel to the position shown in Fig. A to gain access to the backbox.

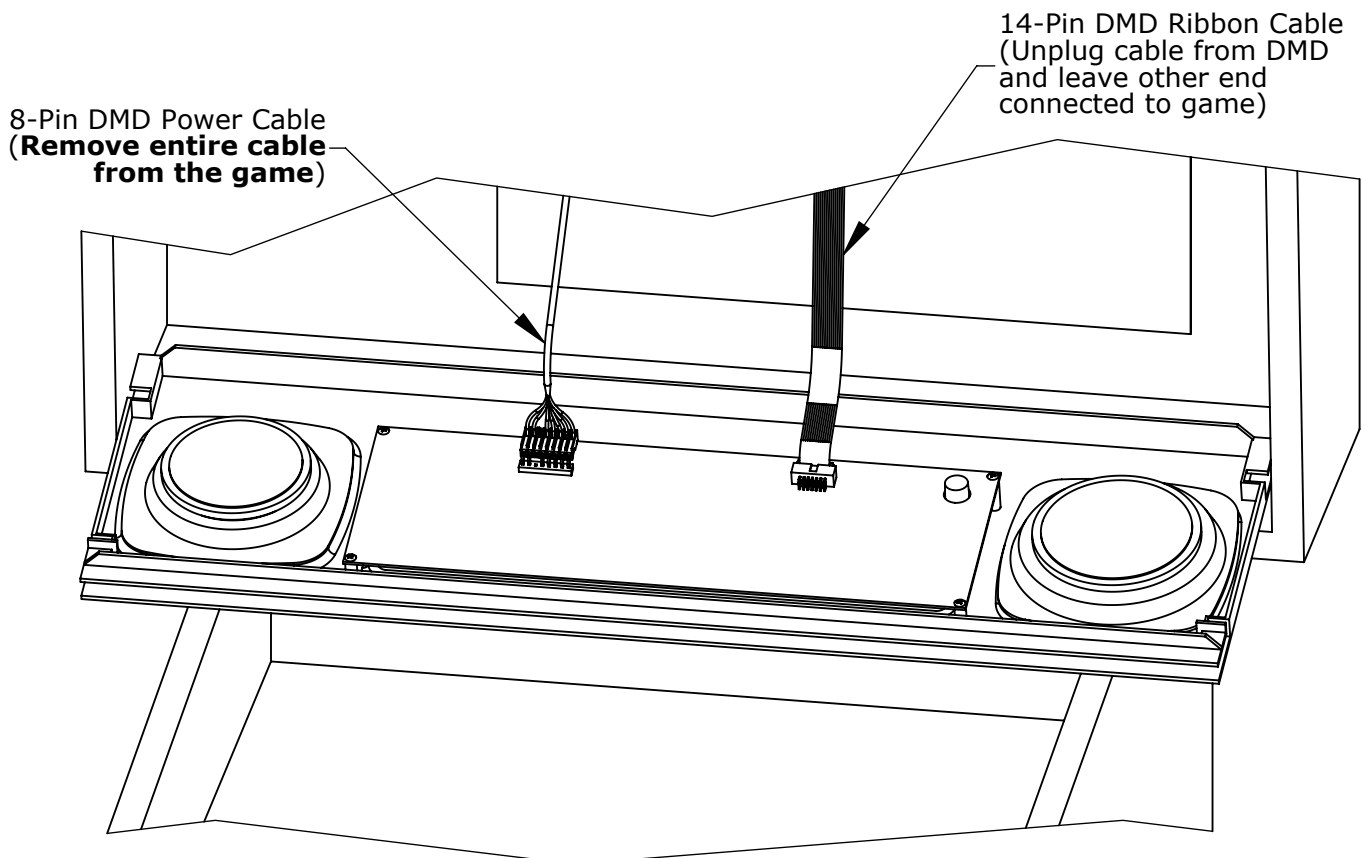

Figure A

- STEP **2** Disconnect the DMD power and ribbon cables from the DMD. Unplug the DMD power cable from the high-voltage A/V board J-604 (see Fig. E), and **remove this cable from the backbox.**
- STEP **3** Remove and save all four DMD mounting screws. Remove the original DMD from the game and store it in a safe place.

STEP **4** Remove the protective film from the front side of the new ColorDMD display.

STEP **5** Position the ColorDMD face down in the orientation shown in Fig. B on the speaker panel and align the four WPC95 mounting holes (see Fig. C).

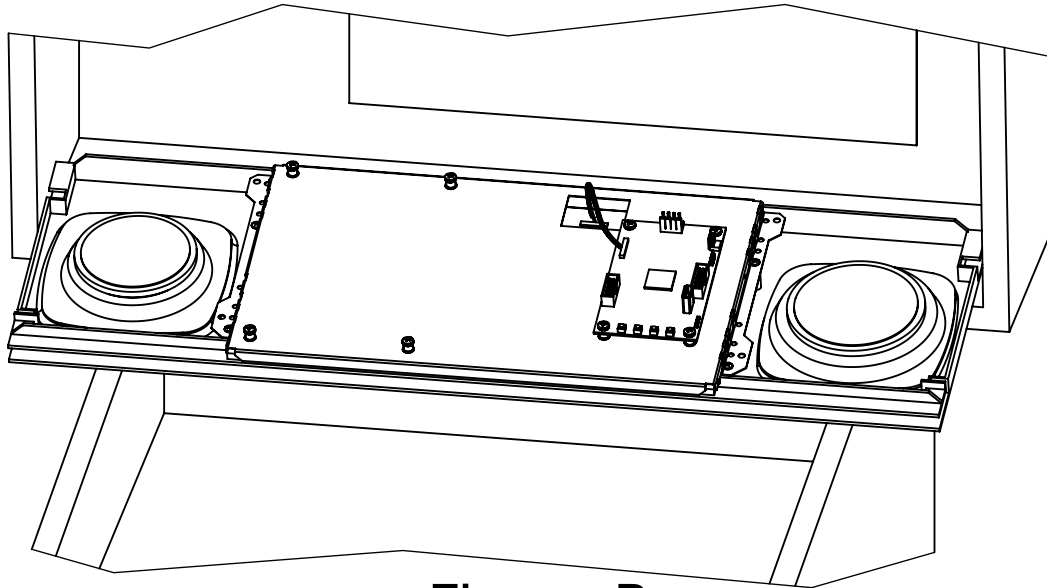

Figure B

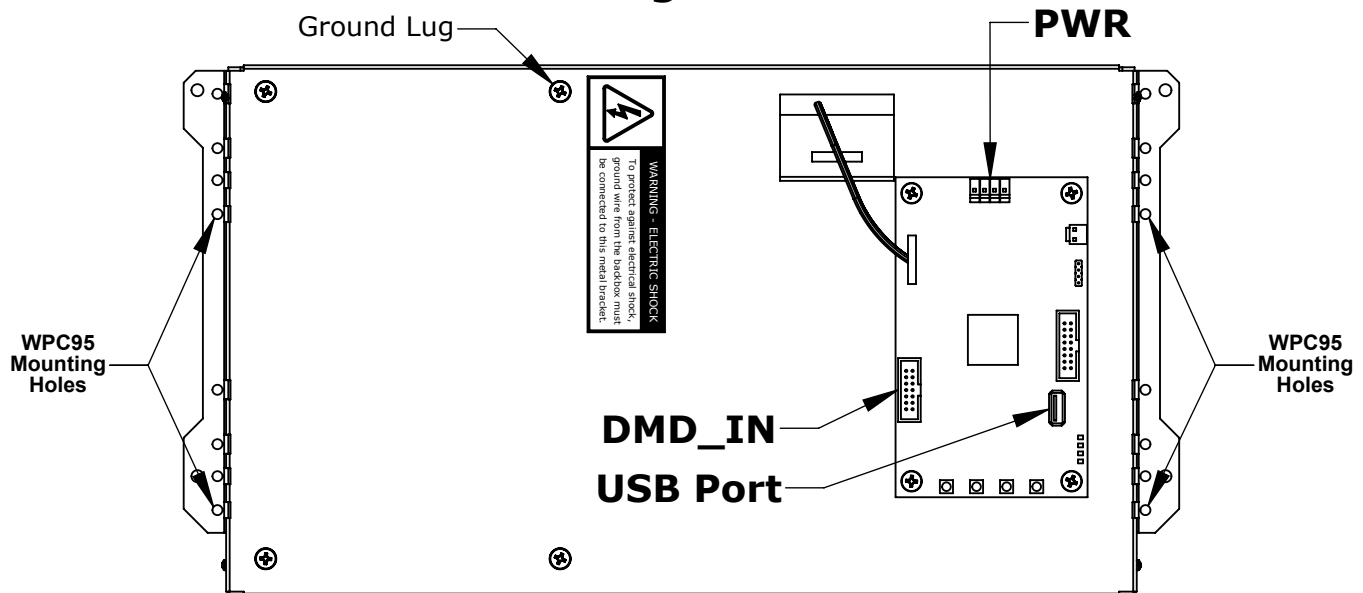

Figure C

STEP **6** Use the four original DMD screws from Step 3 to fasten the ColorDMD display to the speaker panel. If one of the screws is attached to the ground wire from the backbox, ensure that the ground wire is making good contact with the ColorDMD metal bracket. The ground wire can alternately be connected to the provided ground lug on the metal bracket (see Fig. C).



WARNING. Electric Shock Hazard - To protect against accidental electric shock, **DO NOT** operate the game without ensuring that the ColorDMD metal bracket is electrically grounded.

STEP **7** Locate the included 4-pin ColorDMD power cable. One end of the cable has a single connector (see Fig. D). Plug this connector into the PWR header (see Fig. C) on the ColorDMD.

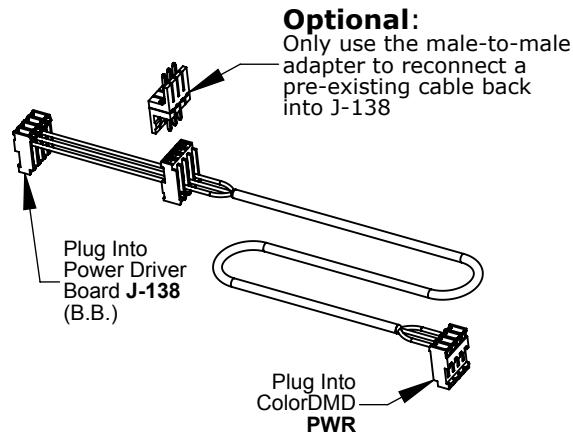

Figure D

STEP **8** Plug the other end of the new ColorDMD Power Cable (see Fig. D) into J-138 on the WPC95 Power Driver Board (see Fig. E). If an existing cable is currently plugged into J-138, disconnect it before connecting the ColorDMD power cable.

TIP

Route the new ColorDMD Power Cable along with the existing cables for a clean install.

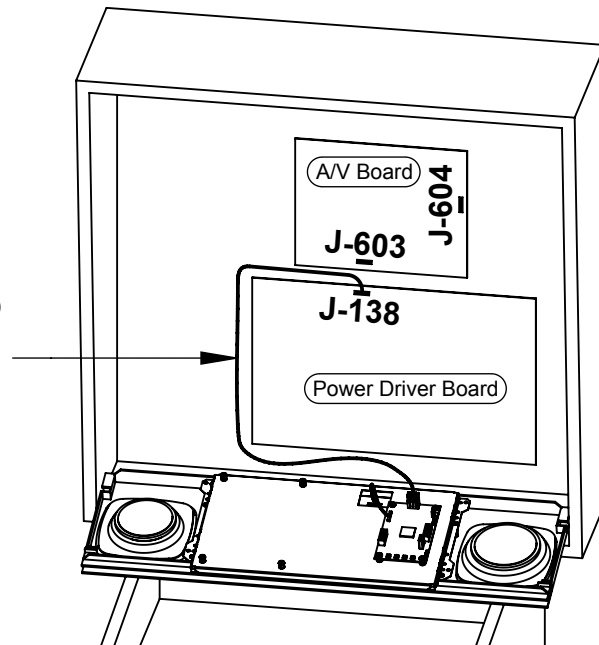

Figure E

STEP **9** If you disconnected a cable from J-138 in the previous step, use the included male-to-male adapter to re-connect this cable to the available center connector on the ColorDMD cable (see Fig. D). Otherwise, do not connect the male-to-male adapter and store it in a safe place.

- STEP **10** Plug the 14-Pin ribbon cable into DMD_IN on the ColorDMD with the **red stripe nearest the top side** of the speaker panel (see Fig. F). The other end of this cable should still be plugged into J-603 on the A/V Board with red stripe on the left-hand side (see Fig. E).

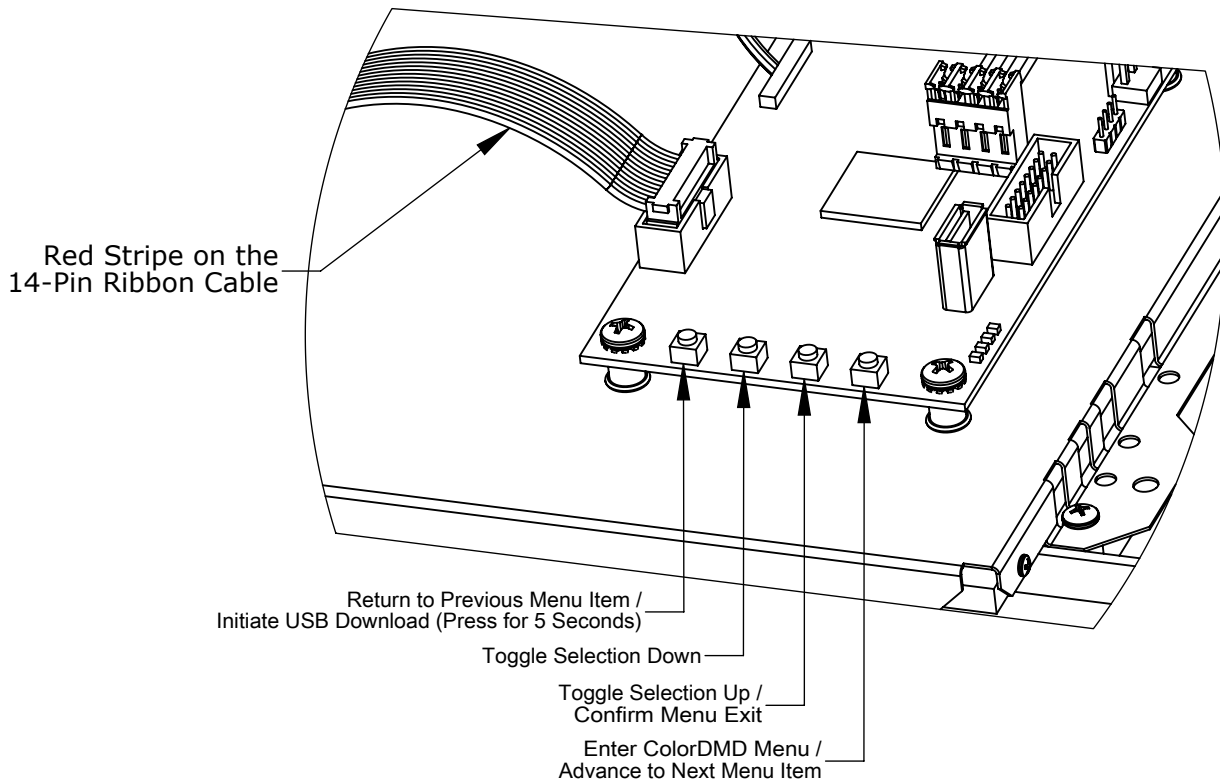

Figure F

! *Double check for proper alignment of **all** cable connections.*

- STEP **11** While ensuring no wires get pinched, raise the speaker panel and turn on the pinball machine.

- STEP **12** Locate and press the right-most *ColorDMD Menu* button (See Fig. F) to customize the display settings. Continue pressing the button to advance to the "MOUNTING" menu. Next use the *Toggle Selection Up* button to change the setting to "WPC95".

- STEP **13** Press the right-most button to advance to the "EXIT AND SAVE" menu. Press the *Confirm Menu Exit* button to save settings and return to game mode. Video should appear on the new ColorDMD Display. Game is now ready to play. Have fun!

For additional information regarding display settings please visit our website at www.colordmd.com.